

"Basket" Strainers

OIL & GAS

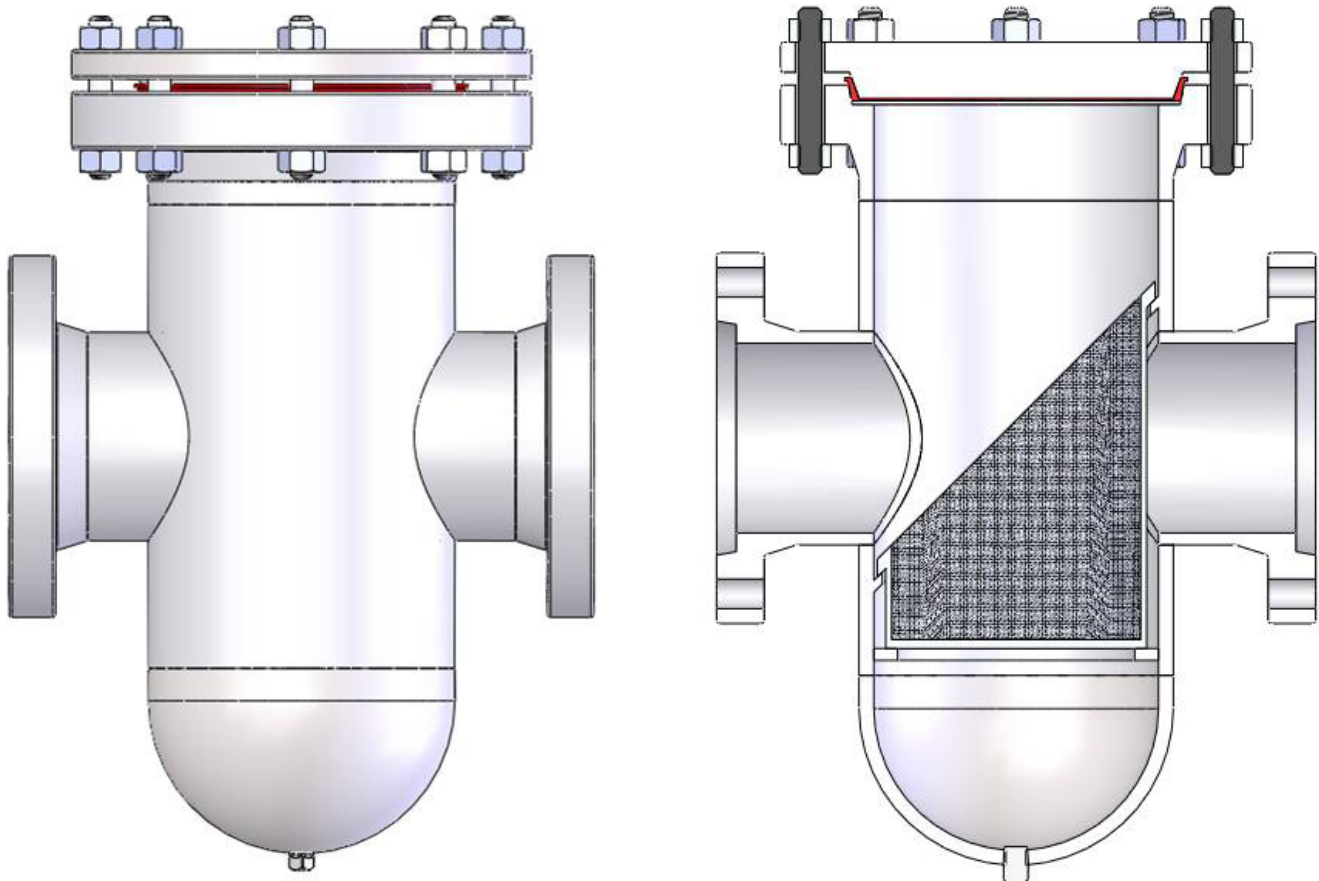

Horizontal Run with Sloped Basket shown

Fabricated Strainers are available in standard designs as shown and feature the patented *Taper-Lok zero leak seal system. Standard Strainers are designed and built in accordance with ASME B31.1, B31.3, B31.4, B31.8, ASME Code Section VIII, Division 1. Standard Strainers are available in ANSI 150, 300 and 600 pound classes. Standard housing material is carbon steel. Special materials such as 304SS or 316SS can be furnished upon request. Internal coatings or liners are available. Fabricated Strainers can be supplied in any ANSI flange rating and facing, or beveled for welding ends. Custom Strainers can be designed and manufactured to meet your specific requirements.

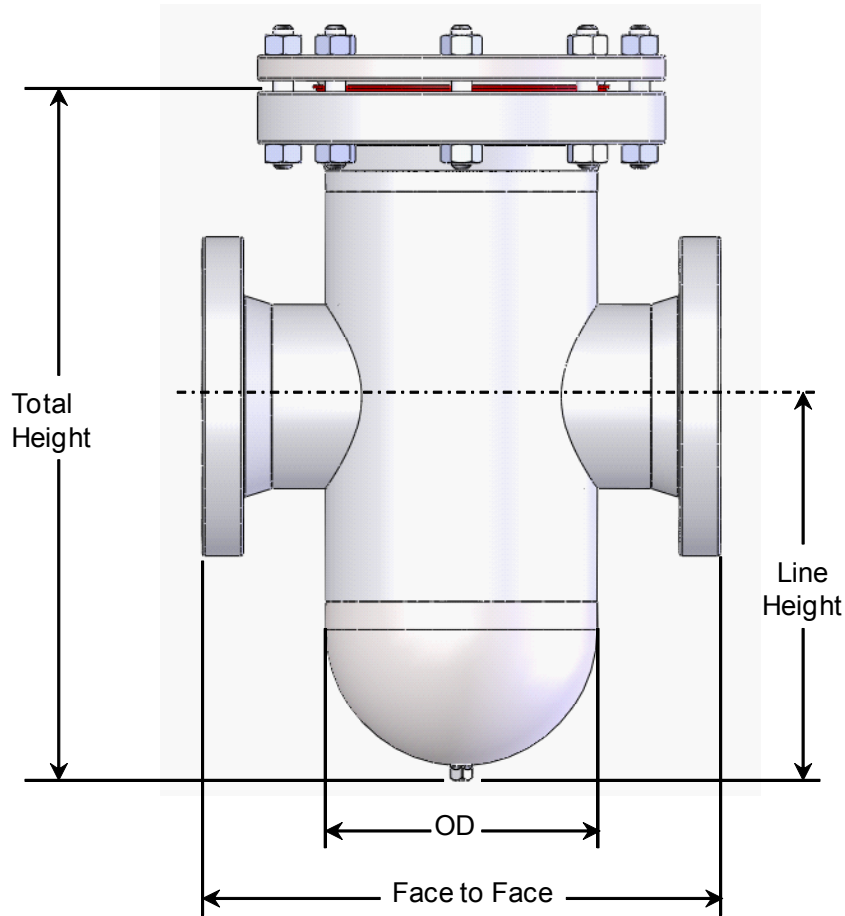

Line Size	OD	Face to Face	Overall Height	Drain Size	Line Height	Sloped Top Basket Area	Flat Top Basket Area
2	4-1/2	17	16	1	9	44	66
3	6-5/8	20	20	1	11	99	140
4	8-5/8	23	24	1-1/2	14	207	245
6	10-3/4	26	29	1-1/2	17	330	366
8	12-3/4	30	35	1-1/2	21	509	550
10	16	34	42	1-1/2	25	792	813
12	18	37	46	2	28	1034	1037
14	18	37	53	2	33	1232	1247
16	24	44	60	2	36	1885	2019
18	24	45	66	2	39	2073	2170
20	26	48	71	2	45	2512	2569
24	30	56	95	2	64	4310	4055
30	36	62	108	2	71	5938	5561

* Dimensions shown are in inches.

Contact Us:

13770 Industrial Rd.
 Houston, TX 77015
 Phone: 713.393.4200
tubularproducts@ameriforge.com